

# **DURA CLUTCH**

PRECISION PERFORMANCE

## DURA CLUTCH INSTALLATION

**15-630 631 632 K-DC- RZR 1000 MY14-15 XP AEBS RXS**

SVI, LLC 21AUG2025 Rev 2

KIT PART #: 15-630 631 632

MODEL: K-DC-RZR 1000 XP AEBS RXS

DESCRIPTION: MY2014-2015 RZR XP 1000 ALL MODELS

### KIT CONTENTS:

1. 10-288 ASM-DCPRIM 26G EBS1000 RXS **(15-630)**  
10-367 ASM-DCPRIM 22G EBS1000 RXS **(15-631)**  
10-368 ASM-DCPRIM 20G EBS1000 RXS **(15-632)**
2. 25-146 SHOULDER WASHER
3. 75-047 SCREW-CLUTCH
4. 99-024 TOOL-12MM BIT SOCKET 3/8 DRIVE (SUBSTITUTE 99-007 TOOL-12MM BIT SOCKET 1/2 DRIVE)
5. 10-371 SECONDARY CLUTCH 9.5 PREM ROLL
6. 75-053 SCR-HXFL-M10X1.25X100 10.9 ZOD
7. 90-056 WASHER-0.406X1.25X0.125 BELLE-Y
8. 90-060 QTY 5 SHIM 0.922X1.015X0.036
9. 90-061 QTY 1 SHIM 0.922X1.015X0.060
10. 99-036 VIBRA-TITE 122 1.8ML THREADLOCKER
11. 35-063 BELT
12. 30-091 TOOL-BELT INSTALL
13. 97-066 DECAL-DC CLUTCH HOUSING DASH 35-063
14. 98-066 DURA CLUTCH WARRANTY R SERIES
15. 98-143 INSTRUCTION-INSTALLATION 15-622 630 631 632 (THESE INSTRUCTIONS)

### DURA CLUTCH INSTALLATION

1. If applicable, (varies by model) loosen clamp on hose connected to clutch cover and move hose out of the way. Remove the clutch housing cover and the secondary clutch.

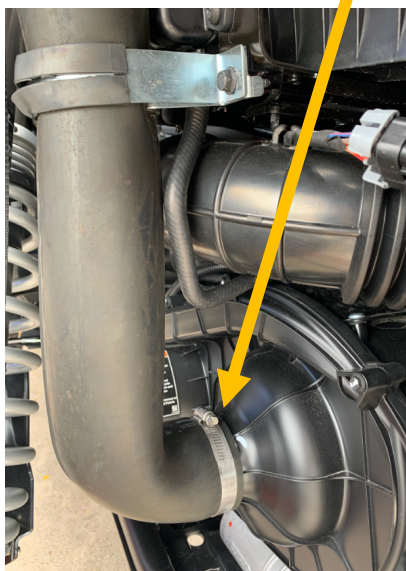

- Place one 90-061 shim and four of the 90-060 shims provided with kit on the transmission shaft up against the spline shoulder.



- Install the DURACLUTCH Secondary. Use the Secondary bolt and Belleville washer provided with kit. Place a drop of BLUE Vibra-Tite provided with kit on the secondary bolt. Tighten the Secondary bolt to 45 ft-lbs.

How Belleville washer is installed on secondary bolt

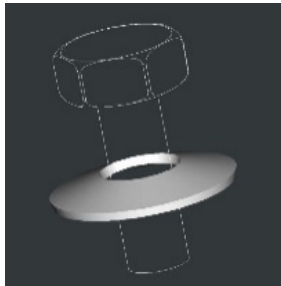

- Remove Primary clutch bolt. Remove the Primary clutch with puller SVI 99-012 (Sold Separately). Greasing the end of the puller slightly will aid in removal. Do not get grease on any clutch components.



- Clean the engine tapered shaft and Primary clutch bore with alcohol or degreaser. Do not lubricate.
- Slip the belt into the Secondary so you can read the part number on the belt and using Belt Install Tool open secondary so belt will seat down into clutch. Sometimes a screwdriver is needed to assist lowering into clutch.



7. Slide belt into primary clutch, then install on post.



8. Install DURACLUTCH Primary with hardware provided as shown below. **VERY IMPORTANT -Torque bolt to 60 ft-lbs. Over tightening will not allow clutch to operate properly and cause damage and failure of the clutch.** SVI PN 99-034 Torque Tool (Sold Separately) shown below to hold the primary clutch when torquing the primary screw.



9. Set belt tension. Place transmission in Park and make sure machine is turned off. Rotate secondary by hand to seat belt in secondary clutch until belt tension is tight.

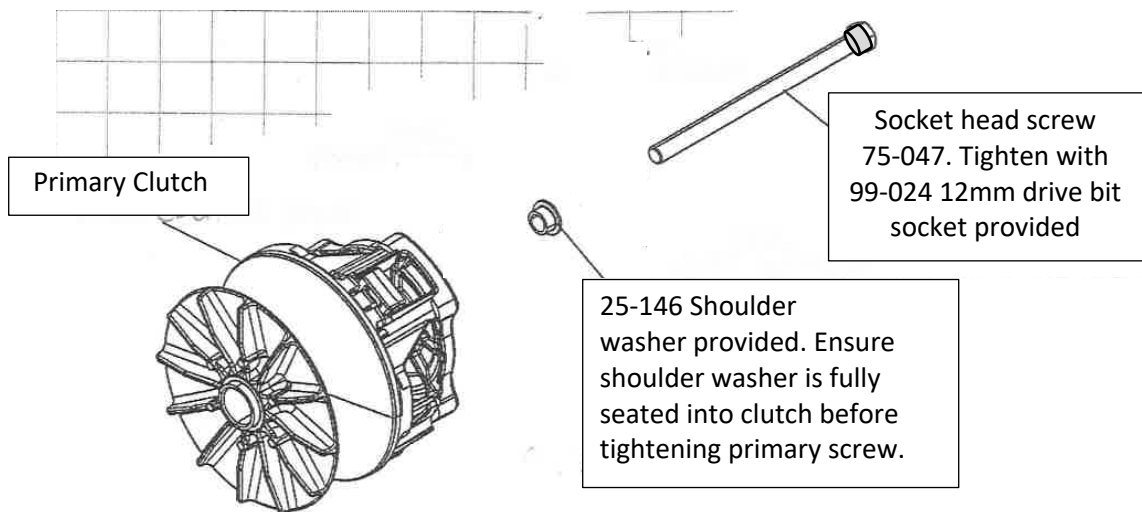

**Do not use original equipment screw or hardware with primary.**

10. Once belt tension is set, start machine and verify that the secondary clutch has slight to no rotation at idle. (If slight rotation this will go away after belt break-in) If slight to no rotation, proceed to step 12. If the secondary is spinning fast, proceed to step 11.
11. If the secondary rotates fast, turn machine off and check to see where the belt is riding in between the primary sheaves. The ideal belt location should be centered with a small gap on each side between the sheaves, a cell phone picture may help see where belt is riding. Follow steps a. or b. to determine the next action.
  - a. If belt is up against fixed sheave (inward), remove belt and secondary screw & secondary and add one shim washer included in kit onto shaft. Install secondary, secondary screw and belt, start machine to reset alignment. If the secondary still rotates fast and rides against fixed sheave, add another shim washer. Repeat until there is slight to no rotation, remember to blue Vibra-tite secondary screw when alignment is complete and torque to spec, proceed to step 12.
  - b. If belt is up against moveable sheave (outward), remove belt, secondary screw & secondary and remove one shim washer. Install secondary, secondary screw and belt, start machine to reset alignment. If the secondary still rotates fast and rides against the movable sheave, remove another shim washer. Repeat until there is slight to no rotation, remember to blue Vibra-tite secondary screw when alignment is complete and torque to spec, proceed to step 12.

To watch a video on R-Series alignment go to our YouTube channel  
<https://www.youtube.com/watch?v=auhmTrhk7Oo&t=17s>

12. Install outer clutch housing. Ensure seal is good or replace with DURACLUTCH seal part # 35-045.  
 Note: The clutch cover screws are hi-lo screws designed for plastic. They can be used over and over in the same hole but must not be over-torqued. Attach hose to clutch cover and tighten clamp.

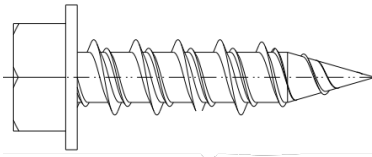

Torque spec: 50 in-lbs (4 ft-lbs). This is like a screwdriver torque. Use a hand wrench or a clutch screw gun at a very low setting.

13. Drive vehicle for 5 miles to break-in DURACLUTCH kit components.

NOTE: If the transmission still shifts hard after break-in there are likely issues other than drag in the clutches. See your dealer or call DURACLUTCH service (218-967-8205).

#### 14. DECALS

Apply two decals as shown – one on the clutch housing and one on the dash. Clean surface with alcohol or similar solvent. Decal applications are important to alert service technicians that the standard Polaris clutches have been replaced.



To watch an installation video, go to [www.duraclutch.com](http://www.duraclutch.com) or our YouTube channel. <https://www.youtube.com/@Duraclutch/videos>