

DURA CLUTCH INSTALLATION

15-529 DC-RANGER1000-Z MY20

SVI, LLC REV3 22JUL2021

KIT PART #: 15-529

MODEL: DC-RANGER1000-Z MY20

DESCRIPTION: MY2020 RANGER XP1000 MY20RANGER CREW 1000XP. This model has the Polaris P90X Clutch. Does not fit MY20 RANGER 1000 (Non-XP). This model has the Polaris P190X CLUTCH.

KIT CONTENTS:

1. 10-174 ASM-DCPRIM WT10-149 SPR50-001
2. 25-146 BUSHING-CLUTCH WASHER
3. 75-047 SCREW-CLUTCH
4. 99-024 TOOL-12MM BIT SOCKET 3/8 DRIVE
5. 99-013 TOOL-T60 BIT SOCKET 1/2" DRIVE
6. 10-220 ASM-DC SECONDARY 9.5 PREM ROLL
7. 3211196 BELT
8. 99-023 LOCTITE 243 0.5ML CAPSULE 1330255
9. 30-091 TOOL-BELT INSTALL 2877408
10. 97-020 DECAL-DC CLUTCH HOUSING DASH 3211196
11. OWNERS MANUAL SUPPLEMENT
12. WEIGHT CHART
13. DURA CLUTCH WARRANTY
14. 98-052 INSTALLATION INSTRUCTIONS 15-529 (THESE INSTRUCTIONS)

DURA CLUTCH INSTALLATION

1. Remove airbox to plenum hose clamps and move hose out of the way.

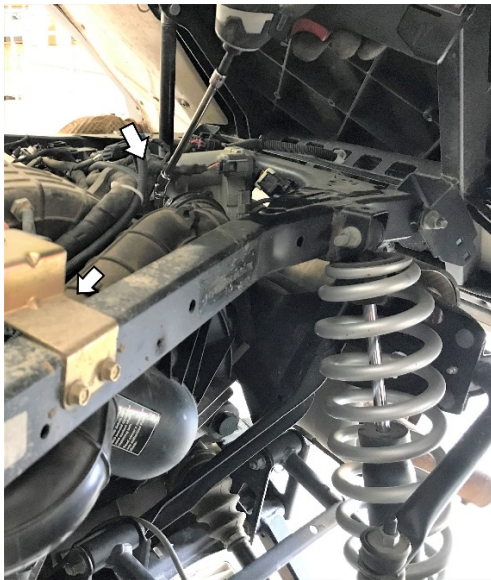

2. Remove the clutch housing cover. Recommended tool: 8mm socket with flex drive extension.
3. Remove Primary clutch bolt. Remove the Polaris primary outer movable sheave assembly. Pull off by hand holding the central shaft in place with your thumb. Move around the clutch, with a pulling and rocking motion.



4. Pull the Polaris primary fixed sheave from the engine crankshaft using PN 99-012 puller. Greasing the end of the puller slightly will aid in removal. Do not get grease on any clutch components.

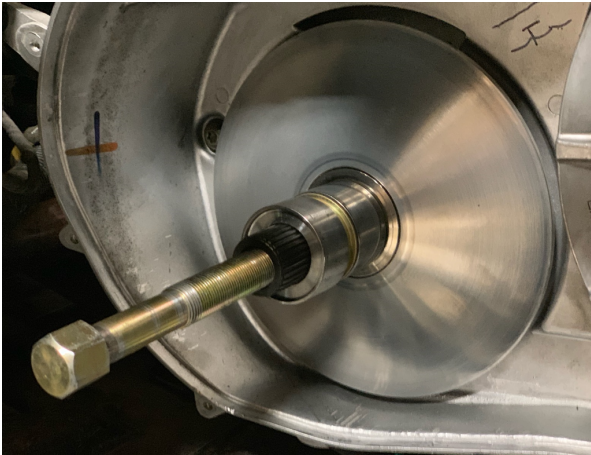

5. Clean the engine tapered shaft and DURACLUTCH Primary clutch bore with alcohol or degreaser. Do not lubricate.
6. Remove the Secondary clutch.
7. Install DURACLUTCH Secondary using stock bolt and washer. Stock shim washers are not used. (see pic below) Place blue Loctite on stock secondary bolt threads and tighten bolt to 45 ft-lbf.



8. Slip the belt into the Secondary so you can read the part number on the belt and using Belt Install Tool open up secondary so belt will seat down into clutch. Sometimes a screwdriver is needed to seat lower into clutch.



9. Slide belt into primary clutch, then install on post.



10. Install DURACLUTCH Primary hardware provided as shown. **VERY IMPORTANT** -Torque bolt to 60 ft-lbf. Over tightening will not allow clutch to operate properly.
11. Once primary is torqued, with transmission in PARK, spin secondary clutch back & forth a few times to allow belt back to top of secondary.

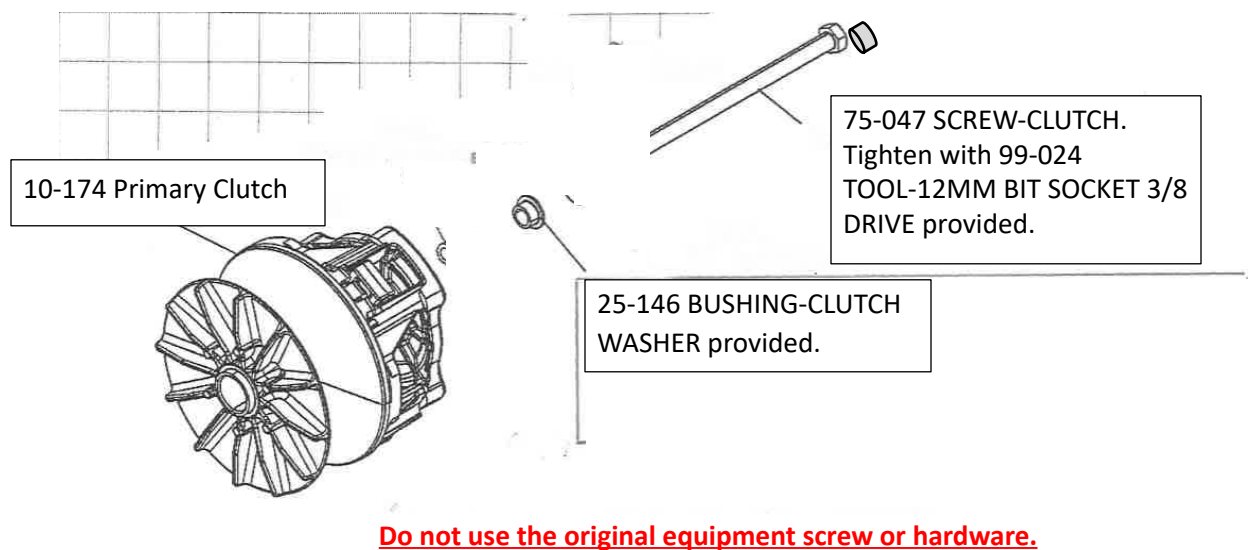

12. How to install a Belt if the Primary and Secondary are already installed. Place Belt in the Primary and open the Secondary sheaves with the Belt Installation Tool provided. Roll belt into the Secondary sheaves. Sometimes a screwdriver is needed to seat lower into clutch.

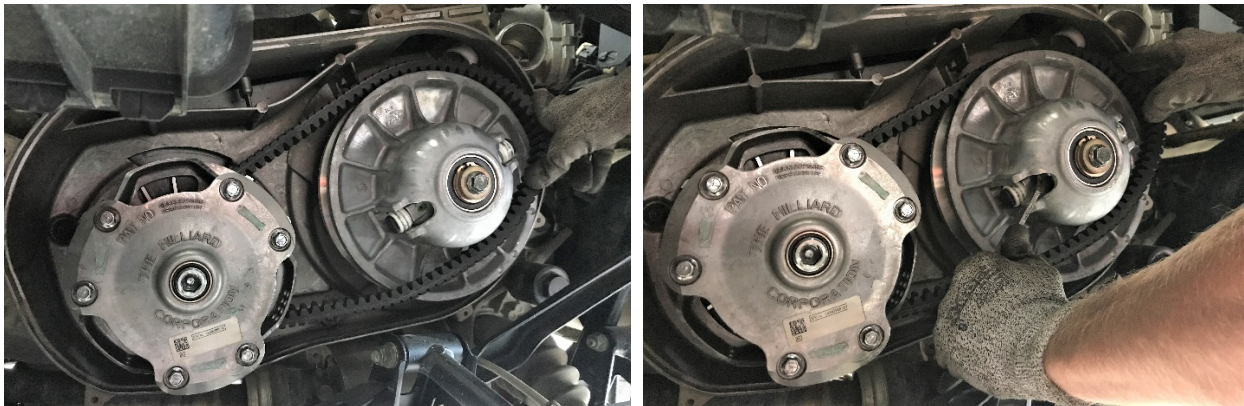

13. Install outer clutch housing. Ensure seal is good or replace.
14. Install airbox to plenum hose removed in step 1.
15. Drive vehicle for 5 miles to break-in DURACLUTCH kit components.
NOTE: If the transmission shifts hard after break-in there are likely issues other than drag in the clutches. See your dealer or call DURACLUTCH service (218-967-8205).

DECALS

16. Apply two decals as shown – one on the clutch cover housing and one on the dash. Clean surface with alcohol or similar solvent. Decal application is important to alert service technicians that the standard Polaris clutches have been replaced.



For installation video go to www.duraclutch.com