

DURACLUTCH INSTALLATION

15-523 DC-GENERAL-2 CALIBRATION UPGRADE KIT

SVI, LLC 18APR2023 REV2

KIT PART #: 15-523

MODEL: K-DC CAL UPGR-GEN-2

DESCRIPTION:

MY16-19 ALL GENERAL MODELS WITH A 15-517 DURACLUTCH KIT INSTALLED UP TO 12/2018 WITH A 10-140 SECONDARY

NOTE: To find secondary part number there is a decal on front and/or is engraved on the back outer edge of sheave.

PURPOSE: This new calibration improves overall performance, especially the transition from clutch pack engagement to CVT low ratio. It also improves clutch pack and belt life and in most driving conditions and provides better fuel economy. The under-hood filter provides clean air for CVT cooling improving durability in dusty riding conditions.

KIT CONTENTS:

1. 10-171 QTY 3, ASM-WEIGHT BUSHED RG-75 TIP REST
2. 50-016 SPRING-PRIMARY 99-277
3. 35-024 BELT
4. 7541906 QTY 3, NUT-10-24-FLEX LOC-Z Weight pin nut
5. 7512266 QTY 3, SCR-SH SHLDR 1/4X2 10-24 OIL Weight pin
6. 10-158 SECONDARY CLUTCH 9.5 PREM ROLL (supersedes 10-140)
7. 75-058 SECONDARY SCREW-M10X1.25X65 8.8 HX ZY
8. 7556130 SECONDARY WASHER-.406X1.25X.125 BELLE-Y
9. 99-023 LOCTITE 243 0.5 CAPSULE
10. 97-047 DECAL-PRIMARY CLUTCH 10-216
11. 95-069 FILTER-CLUTCH INTAKE PRIMARY
12. 98-002 INSTRUCTION- INSTALL 15-523 CAL UPGR GEN-2 (THESE INSTRUCTIONS)



DURACLUTCH REMOVAL

1. Remove the clutch housing cover.
2. Remove Primary clutch bolt. Remove the Primary clutch with puller SVI 99-012 (PII 28772085). Greasing the end of the puller slightly will aid in removal. Do not get grease on any clutch components.
3. Remove belt then Secondary clutch using an impact. If secondary is stuck on shaft thread secondary bolt back into shaft so head is ½ inch away from clutch, hit the head of the bolt squarely with a small hammer while you pull out on the clutch. The vibration will break the secondary clutch loose so you can pull it off. Remove secondary clutch.

Tools needed for disassembly of clutch: 3/8-inch thin wall socket, ratchet, 1/8-inch hex wrench. NOTE: light duty ¼" or 3/8" drive power tools may be used. DO NOT use heavy duty impact power tools for disassembly or assembling primary clutch components.

4. Loosen 6 clutch cover bolts with 3/8-inch socket in an alternating pattern so cover comes up evenly. Mark clutch cover and spider like picture below for reassembly later in step 8. Remove cover bolts and cover.



5. Remove weight pins, weight pin nuts, weights and primary spring.



6. Install new 10-171 RG-75 weights into clutch, install the 3 new weight pins in the same direction and weight pin nuts provided in kit.
With 3/8" thin wall socket and 1/8" hex wrench, tighten weight pins and nuts. Nut will bottom out on shoulder of weight pin.



7. Install new 50-016 primary spring provided with kit.
8. Install clutch cover making sure that the X markings line up on cover and spider. Pull sheave up, push cover down compressing spring to get cover bolts started. Tighten bolts in an alternating pattern. Tighten all screws firmly. Torque spec is 7-11 ft-lbf.



9. Install new 97-047 DECAL-PRIMARY CLUTCH 10-216 on clutch cover.



DURA CLUTCH INSTALLATION

1. Install the DURACLUTCH Secondary. Use the Secondary bolt and Belleville washer supplied with this kit. Do not use O.E. (Original Equipment) hardware. Place a drop of BLUE Loctite on the secondary bolt. Tighten the Secondary bolt to 50 ft-lbf.

Belleville washer placement on Secondary bolt

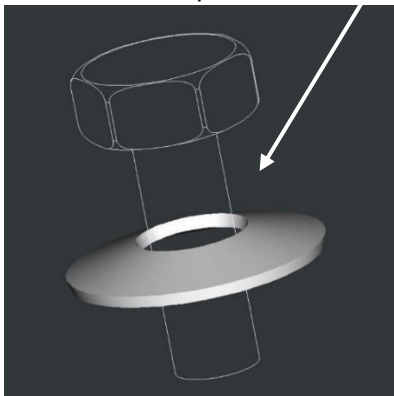

2. Clean the engine tapered shaft and Primary clutch bore with alcohol or degreaser. Do not lubricate.
3. Install Belt & DURACLUTCH Primary.
 - a. Place belt in secondary clutch so you can read the belt part number. Use belt tool to open secondary slightly to allow belt to drop into sheaves.
 - b. Place belt into primary and install onto the shaft. Tighten primary bolt to 60 ft-lbf.
4. Install outer clutch housing. Ensure seal is good or replace with new seal DURACLUTCH Part# 35-045. The DURACLUTCH primary is slightly larger than the original equipment primary. To ensure the primary does not rub against the cover push up and back on the housing while lightly snugging the bottom screws. Then tighten the top rear screw followed by the other top screws. Then tighten all remaining screws including the bottom screws evenly. After starting the engine if you hear the primary rubbing, push on the cover while the engine is running in different directions to see which way will eliminate the rubbing. Stop the engine and loosen the housing screws and retighten using the above sequence while pushing on the cover in the direction that eliminated the rubbing. If this does not eliminate the rubbing, try installing a new, part # 35-045 gasket and go through the bolt tightening sequence again. If you cannot eliminate the rubbing the cover is heat warped and you may have to install a new cover and perhaps a new back plate. You may also try using a heat gun to remove heat sag in the cover.
5. Install 95-069 FILTER-CLUTCH INTAKE PRIMARY. Use instructions provided with filter.
6. Drive vehicle for 5 miles to break-in DURACLUTCH kit components.

For installation video go to www.duraclutch.com