

DURACLUTCH INSTALLATION

15-508 DC-RANGER900-13-02

SVI, LLC REV3 03MAR2021

Kit PART #: 15-508-02
MODEL: DC-RANGER900-13-02
DESCRIPTION: MY13 RANGER 900XP CALIBRATION 02

KIT CONTENTS

1. 10-186 ASM-DCPRIM WT10-170 SPR50-001 (replaces 10-125)
2. 25-146 SHOULDER WASHER
3. 75-047 SCREW - CLUTCH
4. 99-007 TOOL-12MM BIT SOCKET 1/2 DRIVE (SUBSTITUTE 99-024 TOOL-12MM BIT SOCKET 3/8 DRIVE)
5. 10-205 ASM-DC SECONDARY 9.5 PREM ROLL (replaces 10-145)
6. 7518610 SECONDARY SCREW M10x1.25-100MM SCREW
7. 35-024 BELT (substitute 3211148)
8. 30-091 TOOL-BELT INSTALL
9. 97-017 DECAL-DC CLUTCH HOUSING DASH 35-024
10. OWNERS MANUAL SUPPLEMENT
11. WEIGHT CHART
12. DURACLUTCH WARRANTY
13. INSTALLATION INSTRUCTIONS 15-508 (THESE INSTRUCTIONS)

DURACLUTCH INSTALLATION

1. Remove the Secondary clutch.
2. Install DURACLUTCH Secondary using longer secondary bolt supplied with this kit. Tighten bolt to 45 ft-lbf.
3. Remove Primary clutch bolt. Remove the Primary clutch with puller SVI 99-012 (PII 2872085). Greasing the end of the puller slightly will aid in removal. Do not get grease on any clutch components.
4. Clean the engine tapered shaft and Primary clutch bore with alcohol or degreaser. Do not lubricate.
5. Slip the belt into the Primary and over the Secondary.
6. Install DURACLUTCH Primary with hardware provided as shown. Tighten bolt to 60 ft-lbf.

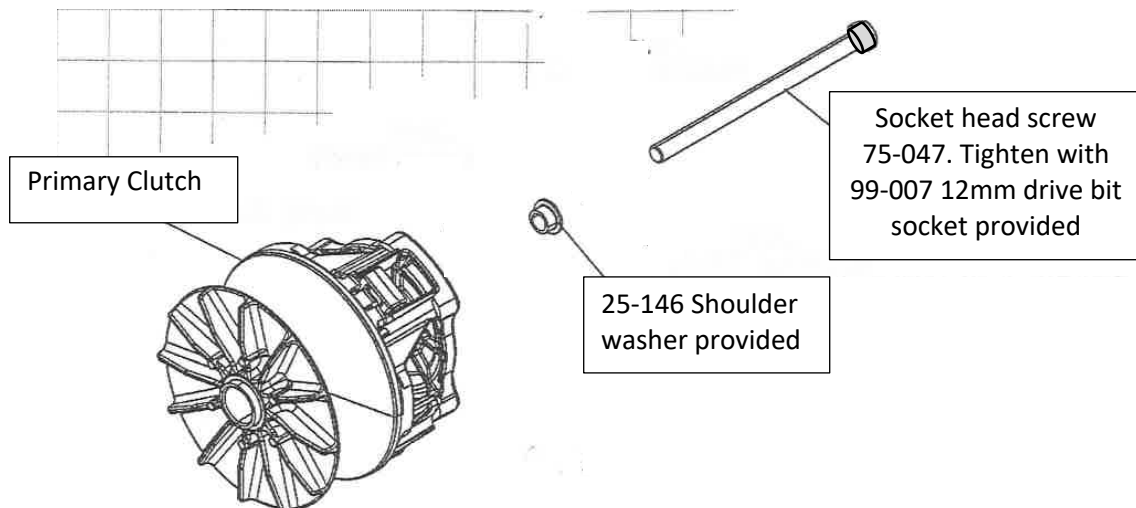

Do not use original equipment screw or hardware.

7. Install the Belt as follows if the Primary and Secondary are already installed. Place Belt in the Primary and open the Secondary sheaves with the Belt Installation Tool provided (see photo). Roll belt into the Secondary sheaves.



8. Set belt tension. Place transmission in PARK! APPLY FOOT BRAKE TO INSURE VEHICLE REMAINS STATIONARY. Apply slight throttle to turn Secondary.
9. Install outer clutch housing. Insure seal is good or replace. The DURACLUTCH primary is slightly larger than the original equipment primary. To insure the primary does not rub against the cover push up and back on the housing while lightly snugging the bottom screws. Then tighten the top rear screw followed by the other top screws. Then tighten all remaining screws including the bottom screws evenly. After starting the engine if you hear the primary rubbing, push on the cover while the engine is running in different directions to see which way will eliminate the rubbing. Stop the engine and loosen the housing screws and retighten using the above sequence while pushing on the cover in the direction that eliminated the rubbing. If this does not eliminate the rubbing try installing a new gasket and go through the bolt tightening sequence again. If you cannot eliminate the rubbing the cover is heat warped and you may have to install a new cover and perhaps a new back plate. You may also try using a heat gun to remove heat sag in the cover.

DECALS

10. Apply two decals as shown – one on the clutch housing and one on the dash. Clean surface with alcohol or similar solvent. Decal application is important to alert service technicians that the standard Polaris clutches have been replaced.

